

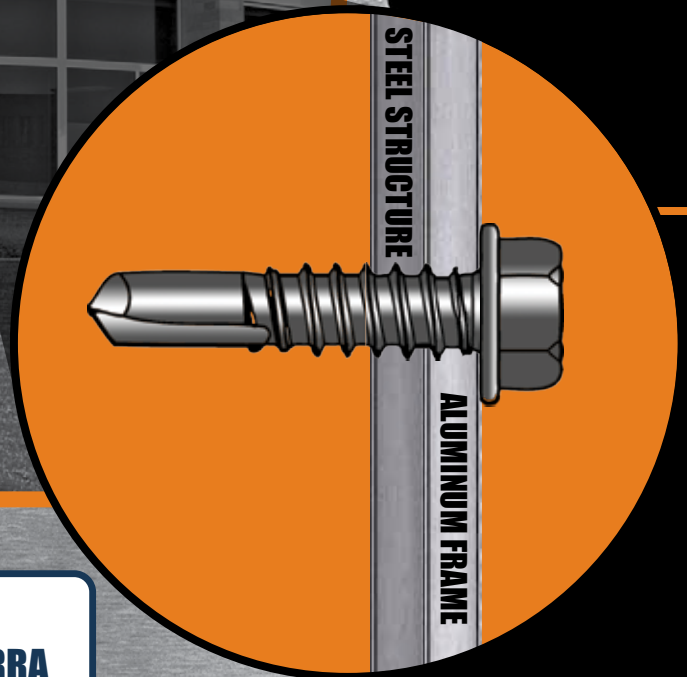

TEKS SELECT™

SELECTIVE HARDENING ATTACHES SIMILAR OR DISSIMILAR METALS
SELF-DRILLING AND TAPPING AND GRADE 5 PERFORMANCE¹ INSTALLS FASTER THAN NUTS AND BOLTS



The Difference Can Last a Lifetime!

GRADE 5 PERFORMANCE

Grade 5 Performance! Designed to attach similar or dissimilar metals, Teks Select fasteners have strength and ductility performance similar to Grade 5 bolts. These characteristics in the fastener's load-bearing area improve resistance to shear failure due to wind and other loads requiring mechanical flex (ductility). This strength and ductility also equips the Teks Select to maintain mechanical integrity when attaching different metals. This attachment can apply shear pressure on the fastener due to the different rates of expansion and contraction (expansion coefficients) present in each type of metal.

An independent 3rd party laboratory tested Teks Selects for strength and ductility performance similar to Grade 5 bolts tested to SAE J429 and ASTM A449. Teks Select hydrogen embrittlement testing was conducted in a 5% neutral salt spray environment per ASTM B117. Fasteners were installed in a wedge plate fixture to induce stress and exposed to over 80% fastener torsion strength of torque every 24 hours for 240 hours resulting in no head pops.



SELECTIVE HARDENING

Teks Select features selective hardening. When dissimilar metals (for example, aluminum and steel) are mechanically fastened and water (from moisture or other sources) is present, a galvanic corrosion takes place. This releases atomic Hydrogen. The presence of the Hydrogen creates the specific conditions in which the Hydrogen assisted stress corrosion cracking (HASCC) or Hydrogen embrittlement of the fasteners may occur. If the fastener material is ductile enough, this situation is prevented. Teks Select's selective hardening process produces drill point and lead threads hard enough (HRC 52 mini-

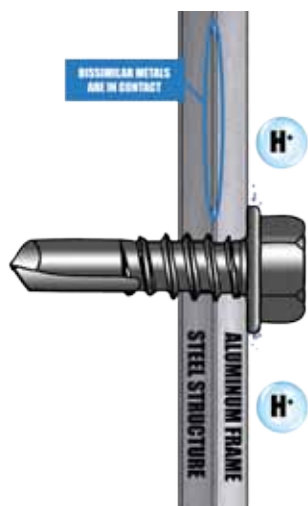

mum) to drill and tap through metals. The load-bearing area remains soft enough (HRC 28-34) to remain ductile accommodating the expansion coefficients of dissimilar metals and resisting Hydrogen embrittlement. And that means the integrity of the connection between the fastened metals is maintained over the life of the building and the building requires less fastener maintenance.

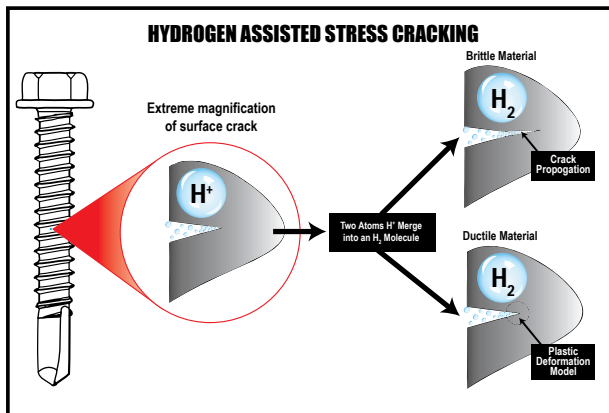

mum) to drill and tap through metals. The load-bearing area remains soft enough (HRC 28-34) to remain ductile accommodating the expansion coefficients of dissimilar metals and resisting Hydrogen embrittlement. And that means the integrity of the connection between the fastened metals is maintained over the life of the building and the building requires less fastener maintenance.

TWICE AS FAST AS NUTS & BOLTS

Self-drilling fasteners can install twice as fast as nuts and bolts. When a job requires a large number of nuts and bolts instead of having to:

- 1) Pre-drill
- 2) Insert the bolt
- 3) Thread on the nut
- 4) Tighten the nut to the required torque

Now these four steps are replaced by one step:

- 1) Install the Teks Select

The Teks Select replaces four steps with one. And that means you save time and money.

ROI CALCULATOR - SELF-DRILLING

	NUTS & BOLTS	TEKS SELECT	SAVINGS
STEP 1 Number of Nuts & Bolts/Fasteners	10,000	10,000	
	X	X	
STEP 2 Installation Time/Fasteners	12 seconds	6 seconds	
TOTAL TIME 60 sec/min - 60 min/hr	33 Hours 33 Mins	16 Hours 39 Mins	= 16 Hours 54 Mins
	X	X	
STEP 4 Labor Rate	\$45.00	\$45.00	
TOTAL COST	\$1500.00 -	\$749.70	= \$750.15

CLIMASEAL ACR COATING

Teks Select features Climaseal Advanced Corrosion Resistance (ACR) coating. This coating enables Teks Select fasteners to outperform competitive fasteners in a 5% neutral salt spray test (conducted per ASTM B117 standards) by both ITW Buildex and an independent 3rd party laboratory. And that means, the work you invest in during fastener installation resists galvanic corrosion and delivers a longer lasting building to **your customer.**

AFTER 1000 HOURS OF 5% NEUTRAL SALT SPRAY EXPOSURE



TEKS SELECT™



ELCO DRIL-FLEX®

and to save time while installing a Grade 5[†] equivalent fastener.



Teks Select™ features the BX head marking. This head marking differentiates a Teks Select fastener from standard Teks fasteners that can offer fewer features. And that means, you are installing a fastener backed by customer service from a world class provider of fastening solutions.

A DRILL POINT THAT STARTS FASTER AND A MORE EFFICIENT THREAD DESIGN

A drill point that starts faster along with a more efficient thread design combine to enable the Teks Select™ to drill and tap up to 40% faster than other drilling and tapping fasteners.

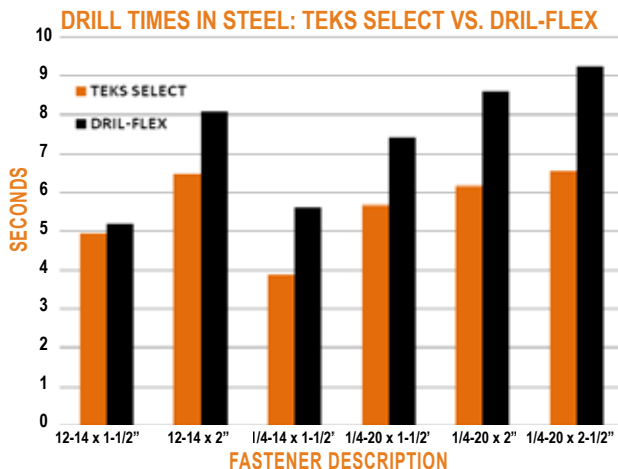

In laboratory tests at ITW Buildex, Teks Select out performed Elco Dril-Flex® in speed tests conducted in a fixture drilling and tapping into steel and aluminum.

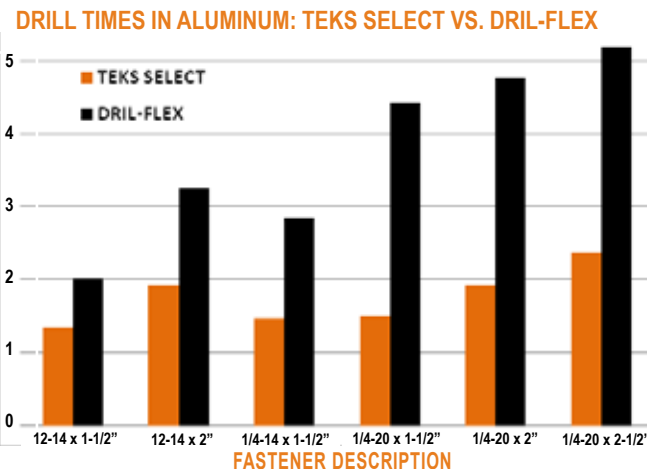

A drill point that starts faster along with a more efficient thread design combine to enable the Teks Select to drill and tap with fewer stalls than other drilling and tapping fasteners.

In laboratory tests at ITW Buildex, using a test fixture, Teks Select drilled and tapped into a 1/4" steel plate, in 20 out of 20 attempts. The competitive fasteners stalled in as many as 8 out of 20 attempts.

COMPETITIVE DRILL TESTING

ROI CALCULATOR - FEWER STALLS

	DRIL-FLEX	TEKS SELECT	SAVINGS
STEP 2 Number of Fasteners Attempted to Install	10,000	10,000	
	X	X	
STEP 2 Number of Fasteners Stalled	3,000	0	
	X	X	
STEP 3 Installation Time/Fasteners	18 seconds	6 seconds	
TOTAL TIME 60 sec/min - 60 min/hr	15 Hours	0 Hours	= 15 Hours
	X	X	
STEP 5 Labor Rate	\$45.00	\$45.00	
TOTAL COST	-	=	\$675.00



APPLICATIONS

Because Teks Select is specifically designed to meet the challenges of attaching similar or dissimilar types of metal, it provides extended fastener life for these applications:







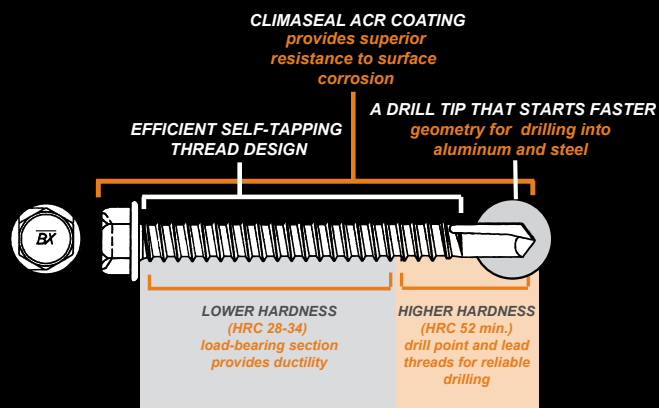

- Glass and Metal Curtain Walls
- Fenestration: Window Systems, Door Systems, and Store Front
- Solar System Attachment
- Grade 5 Nut and Bolt Substitution
- Anchoring Metal Clips to Metal Structures for Masonry Facades

SPECIFICATIONS

Application.....Metal attachments, including aluminum to steel
 Short Form.....Self-drilling and tapping, selectively hardened fastener with
 Specification[†] strength and ductility performance similar to a Grade 5 (1/4-20 diameter) SAE J 429 and ASTM A 449 fastener
 Diameters.....#10, #12, 1/4"
 Thread Form.....10-16, 12-14, 1/4-14, 1/4-20
 Head Styles.....Hex washer head, undercut Phillips flat head
 Drill Point.....Teks® 3, Teks® 4
 Finish.....Climaseal ACR™ corrosion-resistant finish meets a minimum of 1,000 hours salt spray per ASTM B117 standards with 0% red rust

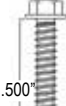
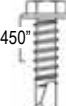
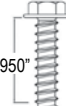

SELECTOR GUIDE & PERFORMANCE DATA

Part Number	1076000	1112000	1080000	1132000	1114000	1117000	1119000	1121000	1124000	1125000	1078000	1126000
Description	10-16x3/4"	12-14x7/8"	12-14x1"	12-14x1"	12-14x1-1/2"	12-14x2"	1/4-14x1"	1/4-14x1-1/2"	1/4-20x1-1/8"	1/4-20x1-1/2"	1/4-20x2"	1/4-20x2-1/2"
Head Style	HWH	HWH	HWH	UPFH***	HWH	HWH	HWH	HWH	HWH	HWH	HWH	HWH
Drill Point	3	3	3	3	3	3	3	3	4	4	4	4
Drilling Cap	.150"	.187"	.187"	.187"	.187"	.187"	.210"	.210"	.210" - .312"	.210" - .312"	.210" - .312"	.210" - .312"
Max Load Bearing Area*												
Installation Tool	5/16" Driv-Tru™ Socket (P/N: 1513910)	5/16" Driv-Tru™ Socket (P/N: 1513910)	5/16" Driv-Tru™ Socket (P/N: 1513910)	#3 Phillips Bit	5/16" Driv-Tru™ Socket (P/N: 1513910)	5/16" Driv-Tru™ Socket (P/N: 1513910)	3/8" Driv-Tru™ Socket (P/N: 1574910)	3/8" Driv-Tru™ Socket (P/N: 1574910)	3/8" Driv-Tru™ Socket (P/N: 1574910)	3/8" Driv-Tru™ Socket (P/N: 1574910)	3/8" Driv-Tru™ Socket (P/N: 1574910)	3/8" Driv-Tru™ Socket (P/N: 1574910)

PULLOUT VALUES (AVERAGE LBS. ULTIMATE)

STEEL GAUGE	ksi													
		18	45.5	401	400	400	400	400	400	400	475	475		
16	63	699	561	561	561	561	561	561	631	631	827	827	827	827
14	55.5	1010	964	964	964	964	964	964	1062	1062	1258	1258	1258	1258
12	63	1680	1516	1516	1516	1516	1516	1516	1878	1878	1946	1946	1946	1946
1/8	56.9	2183	2149	2149	2149	2149	2149	2149	2320	2320	2685	2685	2685	2685
3/16	65.3		2877	2877	2497	2877	2877	2877	3668	3668	3572	3572	3572	3572
1/4	48.1										4719	4719	4719	4719
5/16	49.1										4699	4699	4699	4699
ALUMINUM 6063-T5	1/8	32.4	745	1008	1008	1008	1008	1008	1017	1017	970	970	970	970
	1/4	32.1		2543	2543	2462	2543	2543	3080	3080	2760	2760	2760	2760
	3/8	27.7									3851	3851	3851	3851

SHEAR VALUES (AVERAGE LBS. ULTIMATE)

STEEL GAUGE*	18-18	996	965	965	965	965	965	965	1100	1100	1026	1026	1026	1026
	18-14	1872	1803	1803	1803	1803	1803	1803	2132	2132	2089	2089	2089	2089
	16-16	1331	1360	1360	1360	1360	1360	1360	1414	1414	1359	1359	1359	1359
	14-14		1815	1815	1815	1815	1815	1815	2439	2439	2357	2357	2357	2357
	1/8-3/16								2636	2636	2748	2748	2748	2748
	3/16-1/4										2881	2881	2881	2881
	12-1/4										2843	2843	2843	2843
ALUMINUM 6063-T5**	1/8-1/8	1526	1846	1846	1846	1846	1846	1846	2087	2087	2106	2106	2106	2106
	1/8-1/4		2488	2488	2180	2488	2488	2488	3328	3328	3062	3062	3062	3062

MECHANICAL PROPERTIES

Yield Strength, F _y Ksi (MPa)	134 ksi 920 Mpa	134 ksi 920 Mpa	134 ksi 920 Mpa	134 ksi 920 Mpa	134 ksi 920 Mpa	134 ksi 920 Mpa	134 ksi 920 Mpa	134 ksi 920 Mpa	134 ksi 920 Mpa	134 ksi 920 Mpa	134 ksi 920 Mpa	134 ksi 920 Mpa	134 ksi 920 Mpa
Tensile Strength, F _u Ksi (MPa)	152 ksi 1054 Mpa	152 ksi 1054 Mpa	152 ksi 1054 Mpa	152 ksi 1054 Mpa	152 ksi 1054 Mpa	152 ksi 1054 Mpa	152 ksi 1054 Mpa	152 ksi 1054 Mpa	152 ksi 1054 Mpa	152 ksi 1054 Mpa	152 ksi 1054 Mpa	152 ksi 1054 Mpa	152 ksi 1054 Mpa

* IMPORTANT: Maximum load bearing area is indicated by brackets.
 ** KSI values are the same as listed in the Pullout Values table.

*** Undercut Phillips Flat Head



1349 W. Bryn Mawr Ave. | Itasca, IL 60143
 800-BUILDEX | www.itwbuildex.com

Teks®, Teks Select® and Cimaseal ACR® are trademarks of ITW Buildex and Illinois Tool Works, Inc.

Dril-Flex® is a registered trademark of Elco, Inc.

©2011 ITW Buildex and Illinois Tool Works, Inc. BX3_rev0611