



TEKS® STAND-OFF

INSULATION FASTENER WITH STOP AND LOCK DESIGN TO PREVENT WALL DISTORTION

FEATURES

- > **STOP AND LOCK DESIGN**
 - Preserves the appropriate stand-off distance between wall and structure resulting in less insulation compression.
 - Prevents fastener over-driving that can distort wall panel.
 - Pre-determined depth of drive provides a physical stopping point as a measurement preventing over-driven or under-driven EPDM washers eliminating potential leaks and increasing the seal.
 - Installs faster than stand-off solutions that require physical spacers or additional building material.
 - Works with 3 - 6" blanket insulation. Contact the building manufacturer for maximum insulation thickness and density allowed.
- > **PATENTED ANTI-BACKOUT (ABOT™) THREAD DESIGN**
 - Provides a stronger fastening point for wall panel.
 - Resists and minimizes backout of fastener, reducing wall push-off.
- > **TEKS® 2 DRILL POINT**
 - Fastener drills and taps into steel from .018" to .095" without pre-drilling.
 - Point to thread ratio reduces strip out.
 - Non-walking point provides fast material engagement.
- > **MULTIPLE HEAD STYLES AVAILABLE**
 - Scots® 300 Stainless Steel Encapsulated Head
 - Maxiseal® Integrated Washer Head
- > **P3 POWDER COATING**
 - Chalk and fade performance equivalent to 70% fluoropolymer coated metal panels.
 - Available in over 100 industry standard colors.
 - Available on both head styles.

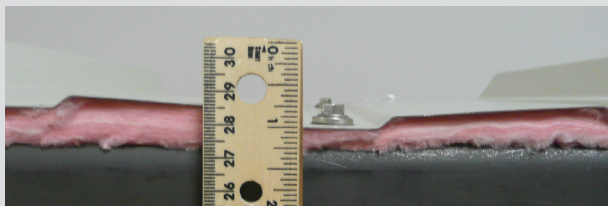

Single Diameter #12 Screw
(26 ga. panel, 17 ga. girt, 6" fiberglass insulation)

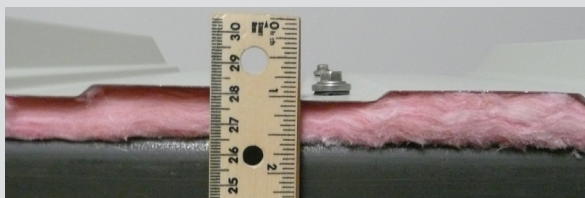

Teks Stand-Off with Scots Head Style (5/8" Stand-Off)
(26 ga. panel, 17 ga. girt, 6" fiberglass insulation)

APPLICATIONS



- > Blanket Insulation
- > Metal Building Sidewall

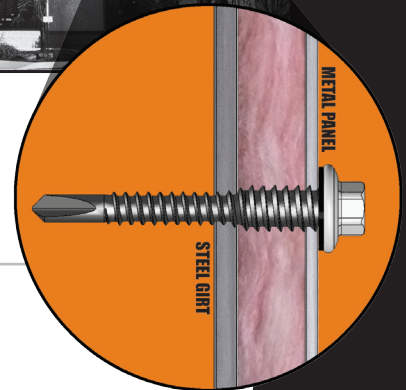

INSTALLATION GUIDELINES

- > A standard screw gun with a depth sensitive nosepiece should be used to install Tek's. For optimal fastener performance, the screw gun should be a minimum of 6 amps and have an RPM range of 0 to 2500 RPM.
- > Adjust the screwgun nosepiece to properly seat the fastener.
- > The fastener is fully seated when the head is flush with the work surface.
- > Overdriving may result in torsional failure of the fastener or stripout of the substrate.
- > The fastener must penetrate a minimum of 3 pitches of thread beyond the metal structure.
- > New magnetic sockets must be correctly set before use. Remove chip build-up as needed.
- > Reference the Selector Guide for the appropriate installation tool.

SELECTOR GUIDE & PERFORMANCE DATA

Part Number	1215053	1303053
Description	17-14 (5/8"); 12-14 X 1-7/8"	17-14 (5/8"); 12-14 X 1-7/8"
Head Style	Maxiseal Hex Washer Head	Scots Hex Washer Head
Drill Point	Teks 2	Teks 2
Drilling Capacity	.210"	.210"
Max Stand-Off	.625"	.625"

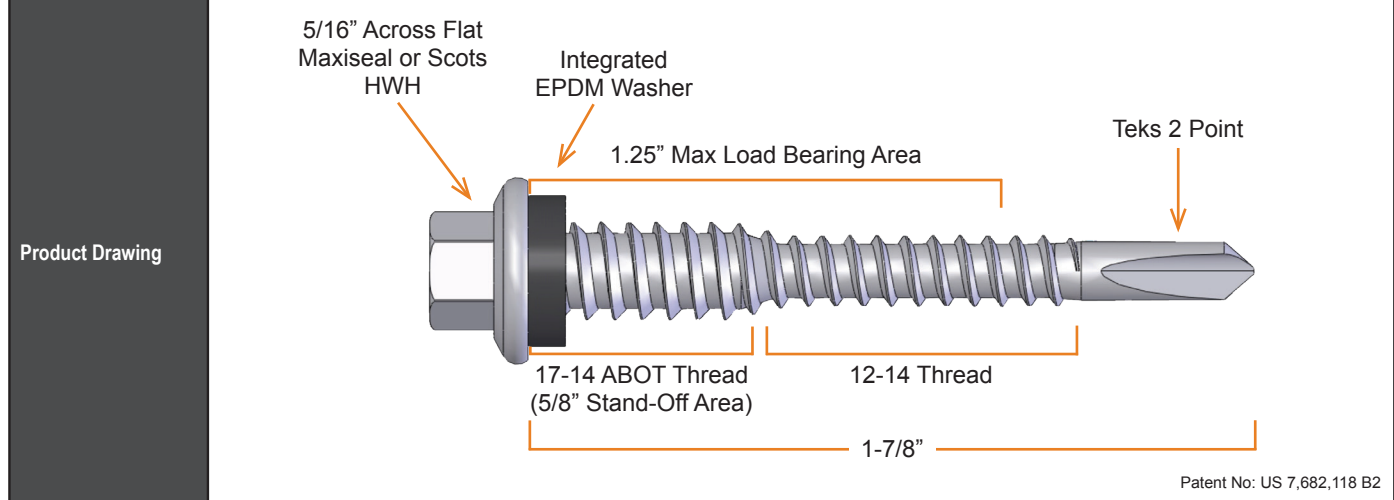

Installation Tool	5/16" Driv-Tru™ Socket (P/N: 1513910)	5/16" Driv-Tru™ Socket (P/N: 1513910)
-------------------	---------------------------------------	---------------------------------------

PULLOVER VALUES (AVERAGE LBS. ULTIMATE)

STEEL GAUGE	panel	girt		
26			686	686

PULLOUT VALUES (AVERAGE LBS. ULTIMATE)

STEEL GAUGE	panel	girt		
		17	985	985

SHEAR VALUES (AVERAGE LBS. ULTIMATE)

STEEL GAUGE	panel	girt		
26	17		602	602

FASTENER MECHANICAL PROPERTIES

Fastener (dia-tpi)	Tensile (lbs. min.)	Shear (avg. lbs. ult.)	Torque (min. in. lbs.)
12-14	2778	2000	92

PRODUCT SPECIFICATIONS

Application Attaches metal exterior wall panels to a building's metal structural members and preserves a specific stand-off distance for insulation.

Description Self-drilling and tapping fastener with dual-diameter design, anti-back-out thread, Teks 2 drill point, Maxiseal head design, Scots head design, and P3 Paint.

Diameter #17 (Stand-Off Area); #12 (Structural Attachment Area)

Thread Form 17-14 (Stand-Off Area); 12-14 (Structural Attachment Area)

Head Style 5/16" HWH Maxiseal
5/16" HWH Scots

Washer Style 9/16" O.D. Integral System

Drill Point Teks 2

Finish Climaseal (tested to ASTM B117 standard - 1,000 hours salt spray)
Available with P3 powder coating



1349 W. Bryn Mawr Ave. | Itasca, IL 60143
800-BUILDEX | www.itwbuildex.com

Teks®, Maxiseal®, Scots®, ABOT™, and Driv-Tru™ are trademarks of ITW Buildex and Illinois Tool Works, Inc.
© 2012 ITW Buildex and Illinois Tool Works, Inc.
BX77_rev0112